

WETMIX™ Bags

Mortar Mixers with Bag Feed Hopper

quick return on investment



WETMIX™ Bags

Mortar Mixers with Bag Feed Hopper

WETMIX™ Bags is a continuous horizontal, single-shaft mixer manufactured from SINT™ER engineering polymer, suitable for all dry premixed building materials delivered in bags, such as mortars, plasters, slags and adhesives which require the addition of water to be ready to use.

After breaking the bag on the cutters placed on the hopper grille, the content flows into the feed hopper of the mixer. The feeder screw on the bottom of the hopper feeds the material into the mixing chamber where water is added. After a few seconds the ready mixed material exits through the front outlet of the mixer unit.

Features



Used in combination with BLOBOY™ (Pneumatic Conveying System), WETMIX™ Bags is the perfect solution for on-floor operation.



Overall Dimensions

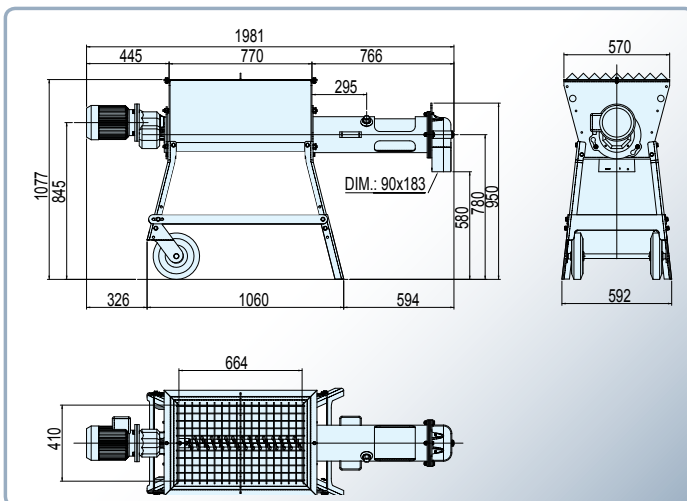

2.2 kW version (single phase/3 phases)

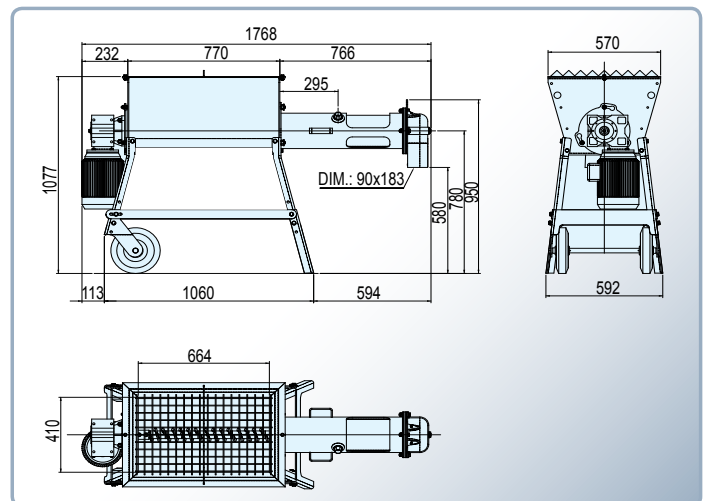

3.0 kW version (3 phases)

Benefits

- ✓ Homogeneous wet mortar within seconds;
- ✓ Manufactured from anti-wear material;
- ✓ Reduced maintenance and cleaning time;
- ✓ Adjustable in height;
- ✓ Cost and time-saving;
- ✓ Quick Return On Investment.

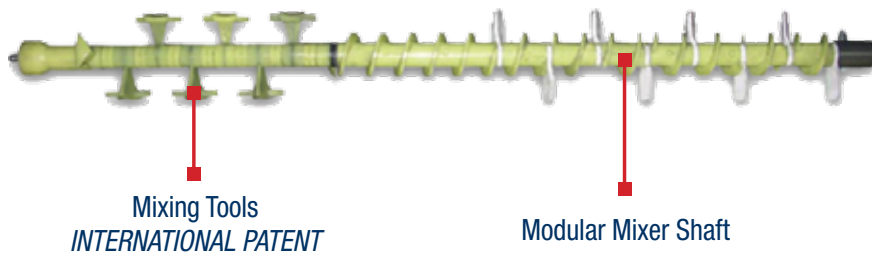
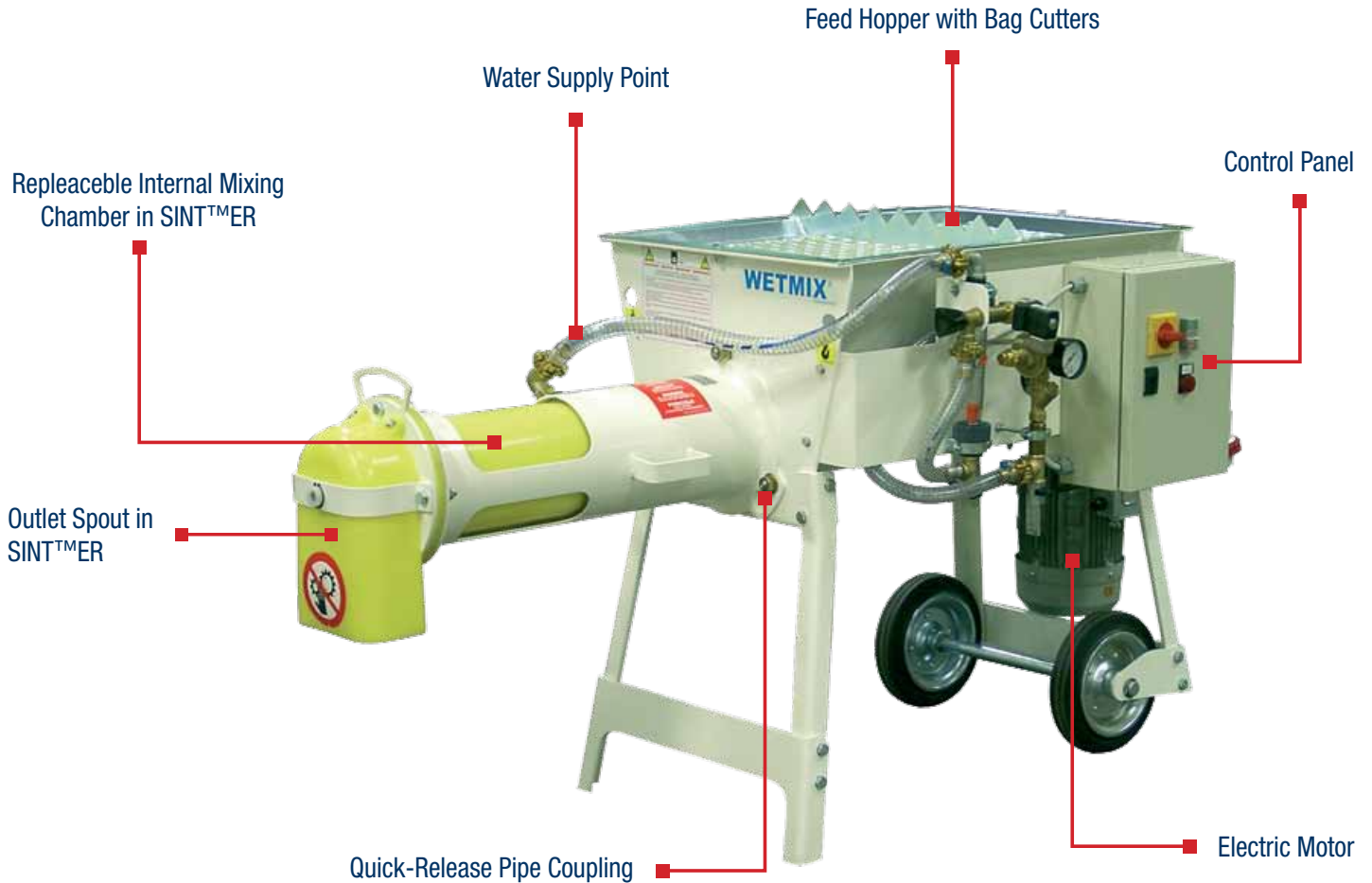

Accessories

Control Panel c/w Pump and Flow Meter

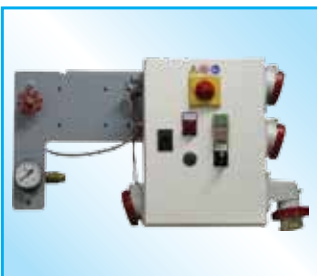

Hood for Pneumatic Conveying System



Electric Cable



Water Hose Pipe Extension



Application



Easy to transport



Simple to use



Perfect mixing quality

013001526 September 2012 Rights reserved to modify technical specifications.



www.wamgroup.com