

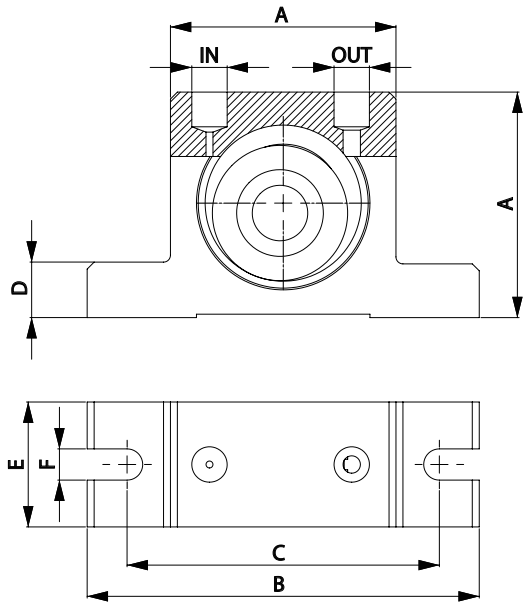

OR - Rotary pneumatic vibrators - Roller



OVERALL DIMENSIONS															
Model	A		B		C		D		E		F		IN-OUT	Weight	
	mm	in	mm	in	mm	in	mm	in	mm	in	mm	in		kg	lbs
OR50	50	1.97	86	3.39	68	2.68	12	0.47	30	1.18	7	0.28	1/8" BSPP	0.37	0.81
OR65	65	2.56	113	4.45	90	3.54	16	0.63	36	1.42	9	0.35	1/4" BSPP	0.76	1.67
OR80	80	3.15	128	5.04	102	4.02	16	0.63	40	1.57	9	0.35	1/4" BSPP	1.27	2.79
OR100	100	3.94	160	6.30	130	5.12	20	0.79	52	2.05	11	0.43	1/4"-3/8" BSPP	2.60	5.72

FEATURES															
Model	Vibration			F.c. max						Air consumption					
	Vpm			2bar = 29psi		4bar = 58psi		6bar =87psi		2bar = 29psi		4bar = 58psi		6bar =87psi	
	2bar = 29psi	4bar = 58psi	6bar =87psi	kg	lbs	kg	lbs	kg	lbs	l/min	CF/min	l/min	CF/min	l/min	CF/min
OR50	21000	25000	29500	188	413	281	619	355	780	78	2.8	144	5.1	204	7.2
OR65	19000	22000	26000	235	516	439	966	552	1215	100	3.5	198	7.0	296	10.5
OR80	14000	16000	21500	342	752	587	1292	624	1373	122	4.3	255	9.0	378	13.3
OR100	6750	9750	11000	289	637	604	1329	783	1722	132	4.7	284	10.0	412	14.5

OR - ROTARY PNEUMATIC VIBRATORS - ROLLER

APPLICATION	Hopper and silo - piping - chute - concrete compaction
POWDER	Hygroscopic
PROBLEM SOLVING	Friction reduction - compaction

FEATURES

DUTY CYCLE	Continuous
WORKING PRESSURE	From 2 bar to 6 bar (from 29 psi to 87 psi)
PNEUMATIC CIRCUIT	Filter + flow control valve + lubrication + 3/2 ways valve
AIR SUPPLY QUALITY	Class 5.4.4.
WORKING TEMPERATURE	From -20°C to 200°C (from -4°F to 392°F)
MAX NOISE LEVEL	<90 dB(a)
TECHNOLOGY	Roller vibration - high frequency and centrifugal force
ATEX	II 2D CT(X) / II 2G CT(X)
MATERIAL	Aluminium body and brass cover

This information is furnished without warranty, representation, inducement or license of any kind. It is accurate to the best OLI knowledge or is obtained from sources believed to be accurate. OLI therefore assumes no legal responsibility.