

Rotary Valve for Wood Pellets and Chippings RWN

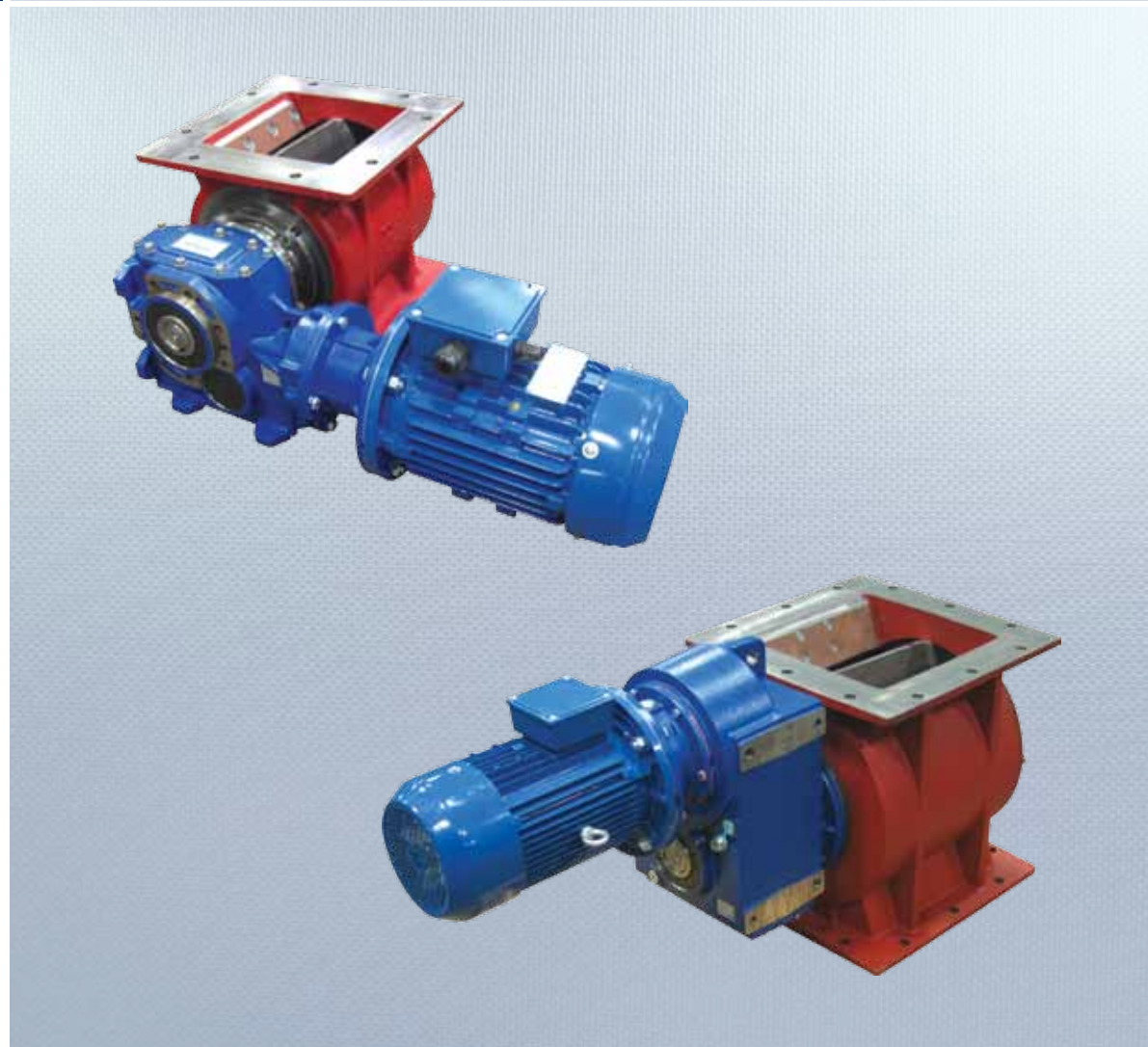

COMPLETE PROTECTION AGAINST BURN-BACK, ENHANCED CUTTING ACTION AND REDUCED COMPRESSIVE FORCES, MAKES RWN THE PERFECT SOLUTION FOR WOOD CHIPS AND WOOD PELLETS APPLICATIONS

RWN Drop-Through Rotary Valves are designed to work with common wood pellets and chippings.

Features

- Square inlet dimensions: 150x150 mm – 200x200 mm – 250x250 mm – 300x300 mm ((6x6" - 8x8" - 10x10" - 12x12"))
- Capacity: 2 – 5 – 10 – 20 litres/rev. (0.07 – 0.17 – 0.35 – 0.7 cu ft/rev)
- Working temperature: from -20°C up to 150°C (-4°F up to 300°F)
- Casing and flange material: cast iron
- Rotor: 4 sharp-edged blades manufactured from hardened steel

Overall Dimensions

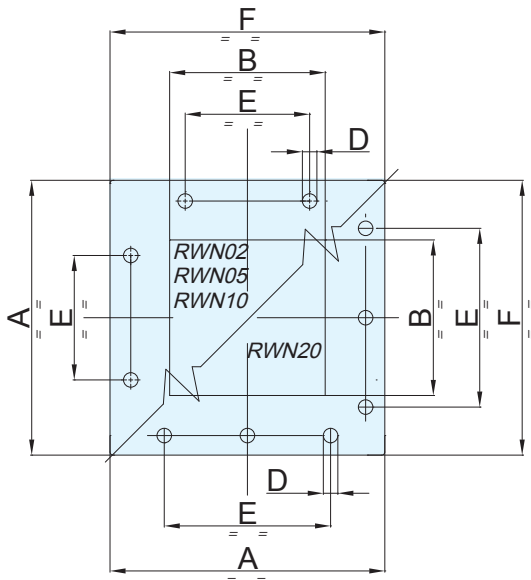

STANDARD DIMENSIONS (mm)					
Type	A	B	D	E	F
RWN02	265	150	14	120	225
RWN05	320	200	14	150	280
RWN10	375	250	14	180	335
RWN20	440	300	18	260	400

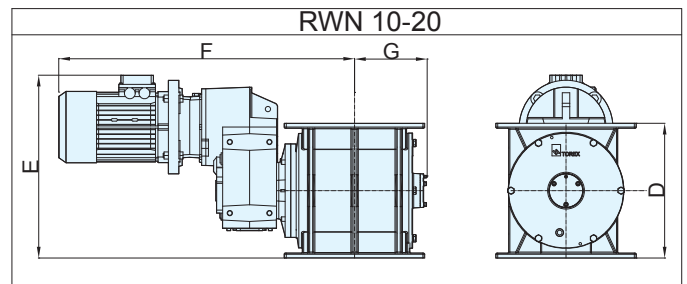
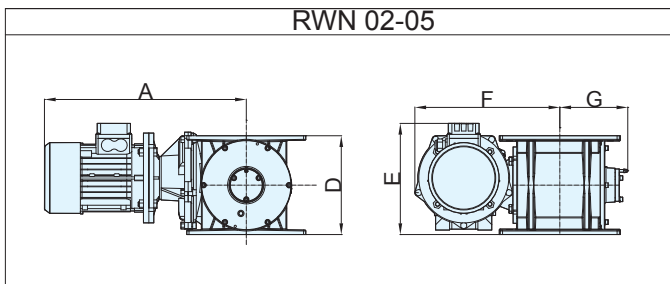

Type	A*	D	E*	F*	G	Rotor Speed (rpm)	Motor Power (kW)
RWN 02	500	220	248	325	131	20	0.75
						30	1.1
RWN 05	540	280	237	340	162	20	1.1
						30	1.5
RWN 10	/	360	490	792	188	20	1.5
						30	2.2
RWN 20	/	455	561	855	226	20	2.2
						30	3.0

(*) dimensions may vary depending on different standards.

Benefits

- ✓ Sturdy, compact structure;
- ✓ Drive unit mounted directly on shaft without further bearing assembly or coupling;
- ✓ Easy access to internal mechanical parts;
- ✓ The shape of the rotor blades manufactured from hardened steel enables the RWN to cut pieces of wood present in the bio-fuel mixture;
- ✓ Certified in compliance with Austrian Directive TRVB H 118/03. Meant to work with wood fuel produced according to ONORM M7132, ONORM M7133 ONORM M7135 standards.

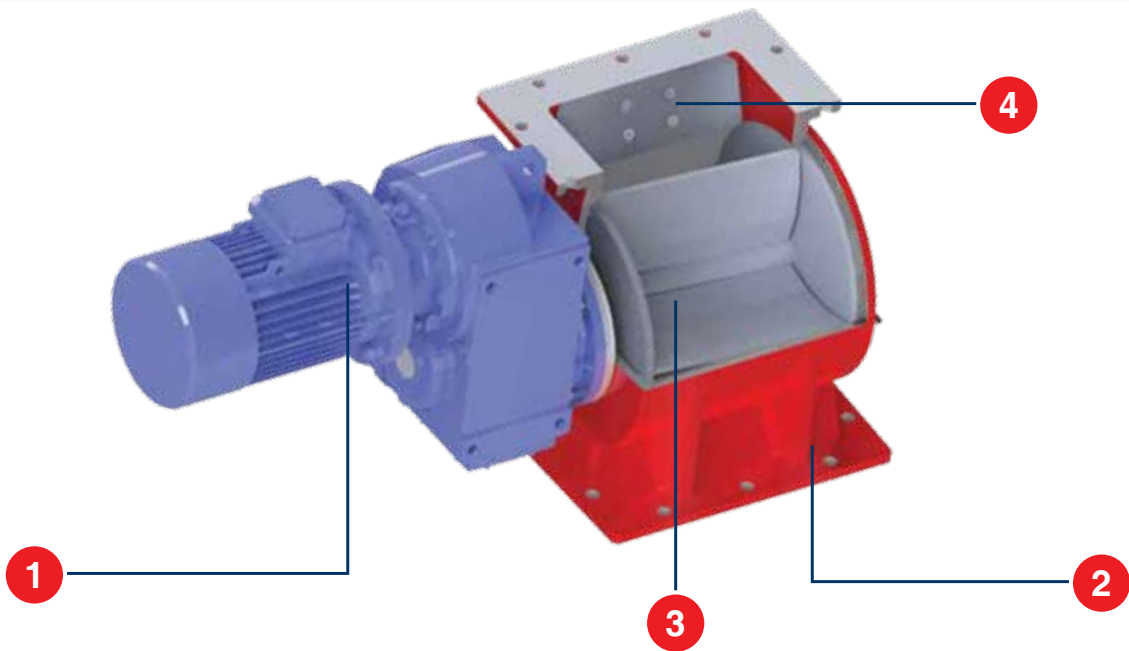

DRIVE UNIT



RWN 10 - RWN 20 Direct Drive (20-30 rpm)

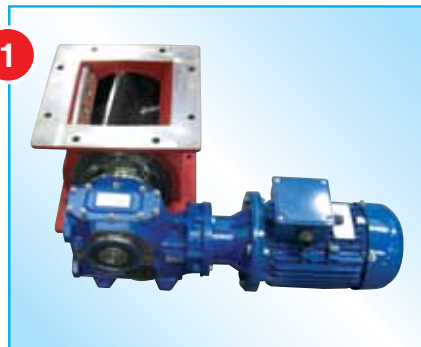

RWN 02 - RWN 05 Direct Drive (20-30 rpm)

CASING



ROTOR



SCRAPER

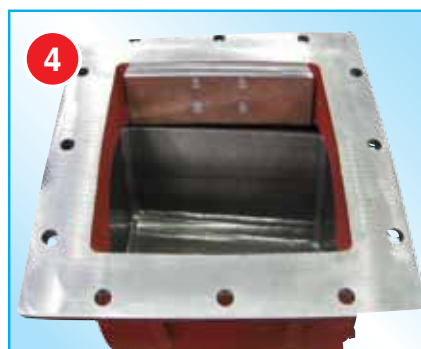

Accessory

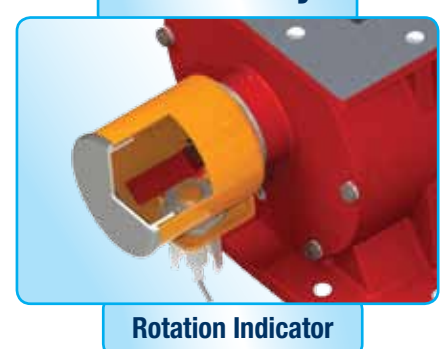

Rotation Indicator

