

In-Piping Screw Screen WASTEMASTER® GCEC - GCPC



SCREW SCREEN IN SELF-SUPPORTING TANK

The WASTEMASTER® GCEC GCPC Screw Screen is a combined machine for the separation of solids present in effluents and the compaction and de-watering of the extracted solids. It is designed to be fed by a pump or by gravity.

The suspended solids are retained by the screen, increasing the liquid level in the front part of the screen. At this point the screw starts operating, cleaning the screen by means of brushes fixed on the outer part of the screw flighting, removing the material, and then de-watering and compacting it (GCPC only).

The machine consists of the following parts:

- Screen;
- Conveyor screw;
- Compactor (GCPC only);

The conveyor screw consists of a shaftless spiral which collects the solids from the bottom of the screen conveying them without risk of clogging.

The compactor in the upper part, equipped with washing section for lowering organic fractions, uses the conveyor screw for compaction and de-watering of the screenings (GCPC only).

Technical features

- GCEC and GCPC have a sturdy metal framework, (completely enclosed structure complying with safety regulations and preventing odours) manufactured entirely from 304L / 316L stainless steel
- Shaftless conveyor screw manufactured from 304 / 316 stainless steel or special high-resistance steel
- Flow rates up to 1,000 m³/h (590 cfm)
- Solids extraction up to 0.33 dm³/s
- Screens have a special mesh suitable for particular characteristics of waste water and solids

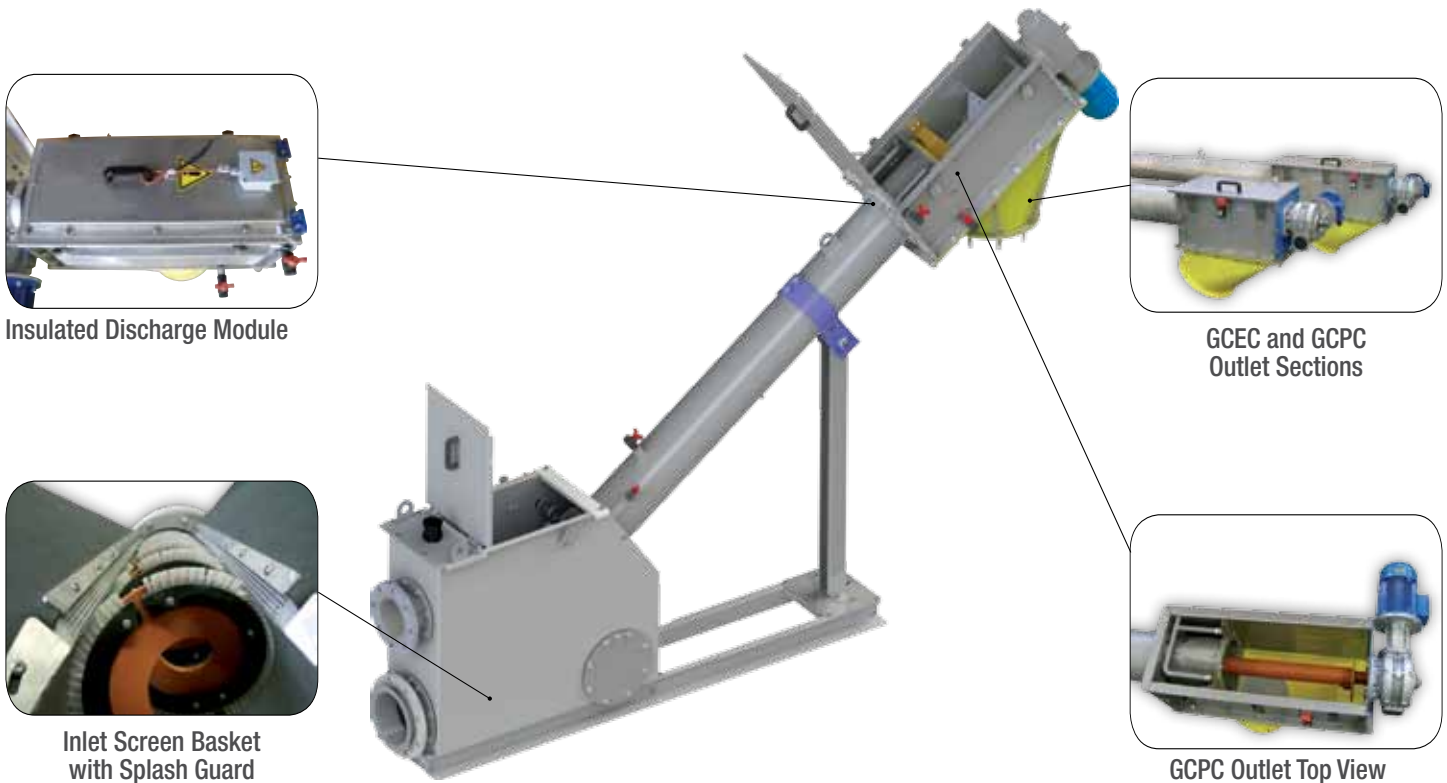

Benefits

- ✓ Screening, conveying and compacting in a single unit using one drive only;
- ✓ Easy installation, low maintenance and low operating costs;
- ✓ Outdoor installation with optional anti-freeze accessories;
- ✓ No clogging even with fibres thanks to shaftless screw design.

Overall Dimensions

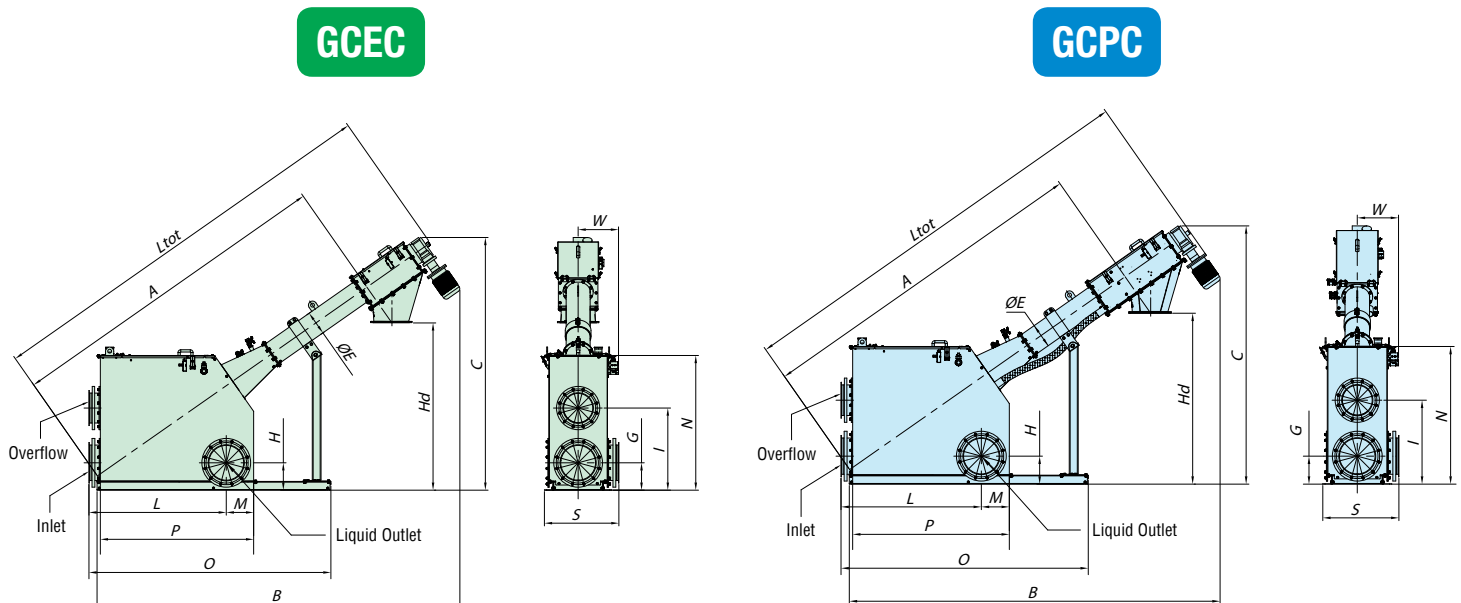

	GCEC 300	GCEC 400	GCEC 500	GCEC 600	GCEC 700	GCPC 300	GCPC 400	GCPC 500	GCPC 600	GCPC 700
A	2,990	2,960	2,955	2,970	3,475	2,990	2,970	2,970	3,080	3,470
B	3,335	3,305	3,305	3,415	3,830	3,300	3,315	3,315	3,505	3,825
C	2,290	2,290	2,300	2,380	2,685	2,290	2,280	2,310	2,435	2,680
ØE	219	219	219	273	273	219	219	219	273	273
G	200	230	250	300	350	200	230	250	300	350
H	200	230	250	300	350	200	230	250	300	350
Hd	1,500	1,500	1,500	1,500	1,500	1,500	1,500	1,500	1,500	1,500
I	645	765	850	980	1,100	645	765	850	980	1,100
L	935	1,205	1,255	1,365	1,505	935	1,205	1,255	1,365	1,505
M	200	200	250	300	350	200	200	250	300	350
N	935	1,180	1,230	1,380	1,580	935	1,180	1,230	1,380	1,580
O	2,200	2,200	2,155	2,275	2,675	2,200	2,200	2,155	2,275	2,675
P	1,030	1,300	1,400	1,560	1,780	1,030	1,300	1,400	1,560	1,780
S	480	580	680	780	880	480	580	680	780	880
W	270	320	370	420	470	270	320	370	420	470
L total	3,690	3,660	3,665	3,820	4,325	3,700	3,680	3,680	3,930	4,320

Dimensions in mm

Accessories

- Bag clamping system
- Endless tube

Application



063022191 July 2013 Rights reserved to modify technical specifications.



www.wamgroup.com