

VBT QuickFlow

One-way air fluidizer for dry bulk tank trailers



POWERED BY TRAMONTANA™ DISK FLUIDIZER (PATENT PENDING)

THE FASTEST LOAD-OUT SPEED TESTED

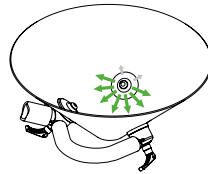

Revolutionary Design

New, innovative & patented shape, designed to maximise system efficiency

AIR FLUIDIZER FOR DRY BULK TANK TRAILER



OLI





VBT Innovative Solutions

New, innovative, revolutionary

The VBT is designed to maximise trailer unloading efficiency: the TRAMONTANA™ disk fluidizer (patent pending) boosts powder discharge speed. The cam lever lock system allows for safe and correct installation. Self-cleaning manifold design.



Food & Pharmaceutical Grade

Made with FDA approved components

VBT SERIES

| | |
|-----------------|------------------------------------|
| APPLICATION | Dry bulk tank trailer, rail tanker |
| POWDER | Dry, fine, granular |
| PROBLEM SOLVING | Bridging and rat-holing |

FEATURES

| | |
|---------------------|---|
| DUTY CYCLE | Continuous (suitable to be used with blower) |
| WORKING PRESSURE | From 0.7 Bar to 2 Bar (from 10 PSI to 29 PSI) |
| PNEUMATIC CIRCUIT | Suitable standard pneumatic bulk trailer, works with all standard designs |
| WORKING TEMPERATURE | From -40°C to 170°C (from -40°F to 340°F) |
| TECHNOLOGY | Vibro-aeration |
| MATERIAL | Blue silicone membrane - metal detectable, comply with FDA 177.2600 Stem - Black polyarylamide glass-fiber reinforced comply with 10/2011/EC - FDA - UL94 Manifold - Black polyarylamide glass-fiber reinforced comply with 10/2011/EC - FDA - UL94 Manifold - Transparent material comply with ISO 10993 - FDA 21 CFR 177.1655 - NSF 51 - UL94 Lever and T-handle - Black polyarylamide glass-fiber reinforced / Stainless steel thread shaft Silicone gasket |

OPTIONS

| | |
|--------------------|-------------------------|
| CAM LEVER | Shaft material: AISI304 |
| HOPPER SAVER PLATE | Stainless steel |
| SILICONE MEMBRANE | White colour |



Components

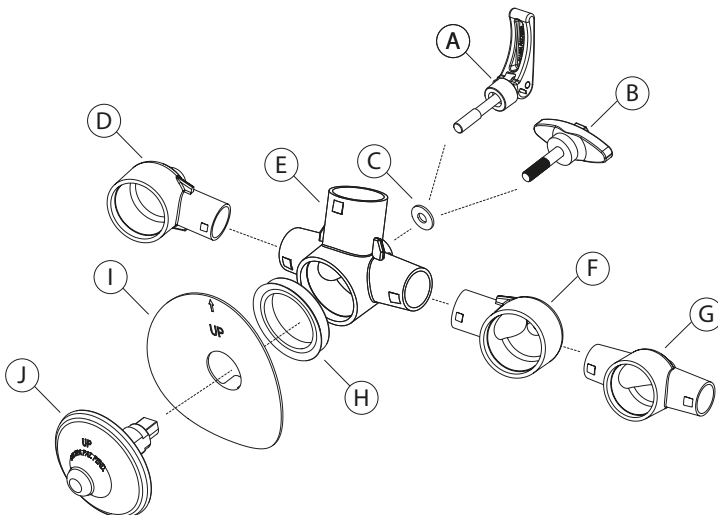

- A - Cam lever lock system - optional
- B - T-handle lock system
- C - Gasket
- D - LH 1way air collector
- E - 3way air collector
- F - RH 1way air collector
- G - 2way air collector
- H - Air collector gasket
- I - Hopper saver - optional
- J - Membrane

INSTALLATION

Dimensions are in cm, within brackets are in inches

45° ANGLE TAPER

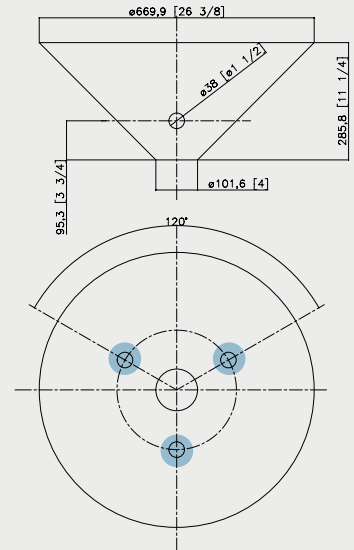

37° ANGLE TAPER

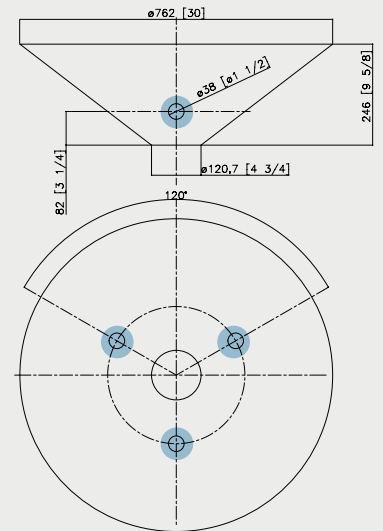

APPLICATION

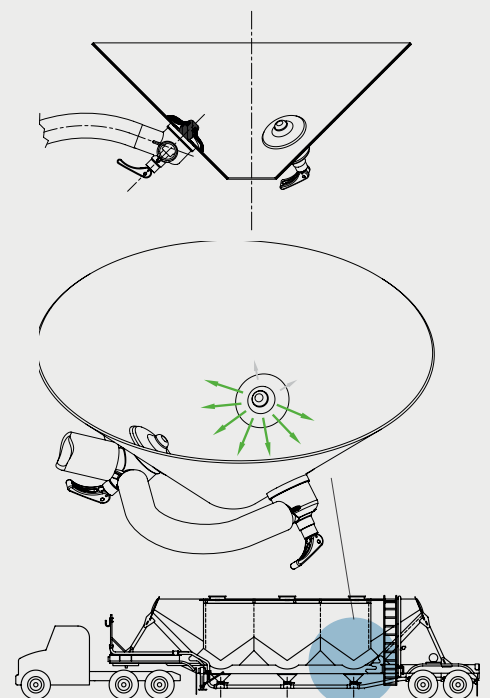

Comparison chart – OLI vs. competitors



DURABILITY

COMPETITORS



| | | |
|----------------------|-------------------------------|---|
| Durable disk | Acceptable | Higher durability due to thicker profile in high wear areas |
| Stainless steel post | Optional | Standard |
| Manifold & stem | Fibre-reinforced grey plastic | High performance, FDA and UL94 engineering polymer compound |
| Max. temperature | 170°C (340°F) (membrane only) | 170°C (340°F) - white or blue membrane (complete unit) |



EFFICIENCY

| | | |
|------------------------|----|---|
| Enhanced air fluidizer | No | TRAMONTANA™ disk: the Venturi style disk cavity of the VBT boosts air flow in the direction of the discharge reducing load-out time |
| Compact manifold | No | Reduced turbulence, increased usable air flow, self cleaning manifold design - Zero powder deposit |
| Easy fit inlets | No | Increased air flow (by reducing tube bends) |
| Dual seal technology | No | Yes |



DESIGN

| | | |
|------------------------|----------|--|
| Smooth disk outer wall | No | Smooth disk outer wall to avoid material sticking to its surface, thus increasing product flow |
| Easy installation | Good | Best |
| Clamping system | T-handle | T-handle as standard - CAM Lever Lock System (Optional) for safe, quick and correct installation |
| Food-grade | Option | Standard |
| Metal detectable disk | No | Standard |
| Interchangeability | Limited | Yes |
| Backflow protection | Yes | Yes |



LOADOUT SPEED

| | | |
|----------------|------|------------------------------------|
| Loadout speed* | Good | 25% faster than closest competitor |
|----------------|------|------------------------------------|

* Based on testing conducted by WAMGROUP and field test. Competitors' data are the ones commercially available on the market. We do not take any responsibility regarding the accuracy of the above data.



FASTER → TRAMONTANA™ disk fluidizer (patent pending)

One-way directional air flow to boost powder discharge

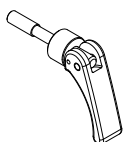

SAFER → Cam lever lock system

Safe and correct installation, optimum operating tension

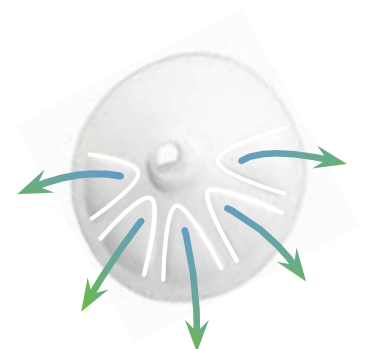

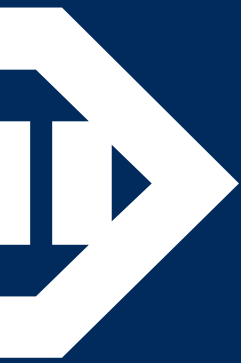

WHEN YOU NEED IT, WHERE YOU NEED IT

THE WORLDWIDE LEADER IN VIBRATION TECHNOLOGY



OLI HEADQUARTERS
VIA CANALAZZO 35
41036 MEDOLLA (MO) - ITALY

PHONE +39 0535 41 06 11
FAX +39 0535 41 06 50
E-MAIL INFO@OLIVIBRA.COM

WWW.OLIVIBRA.COM

WORLDWIDE SUBSIDIARIES

| | | |
|---------------|-----------------|------------------|
| OLI Australia | OLI India | OLI South Africa |
| OLI Benelux | OLI Italy | OLI Spain |
| OLI Brazil | OLI Middle East | OLI Turkey |
| OLI China | OLI Nordic | OLI UK |
| OLI France | OLI Romania | OLI USA |
| OLI Germany | OLI Russia | |

